

TRIM PANEL

REMOVAL

- (1) Disconnect and isolate battery negative cable.
- (2) Using a small flat bladed tool or equivalent, press retaining clip upward through cutout in handle cover and remove cover. (Fig. 17)

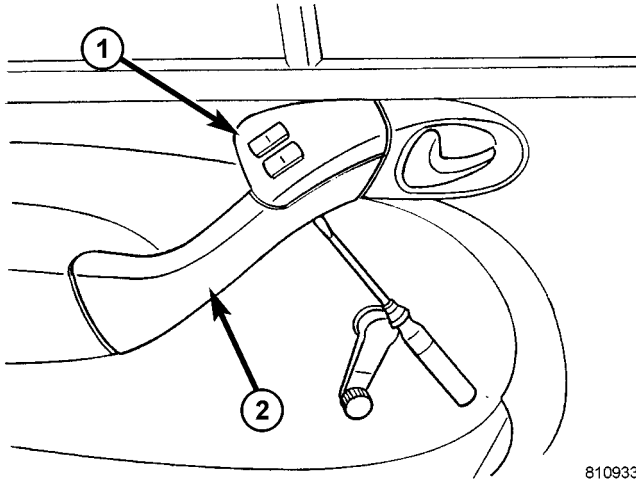

81093341

Fig. 17 TRIM PANEL HANDLE

- 1 - SWITCH BEZEL
- 2 - HANDLE COVER

- (3) Remove switch bezel and disconnect electrical connectors.
- (4) Remove the screws. (Fig. 18)

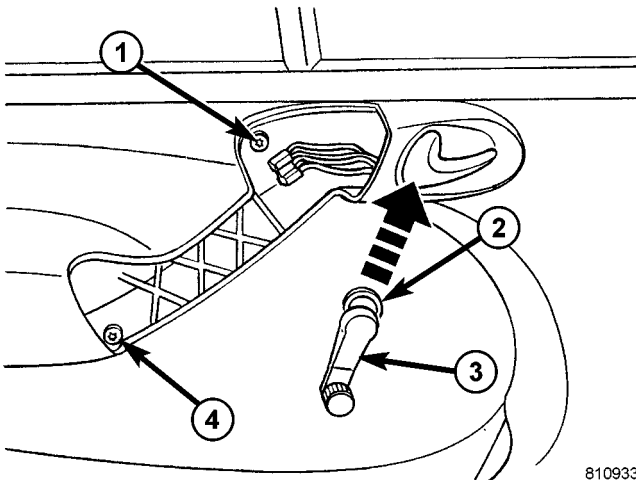

81093350

Fig. 18 TRIM PANEL FASTENERS

- 1 - UPPER SCREW
- 2 - WINDOW CRANK MOUNTING RING
- 3 - WINDOW CRANK
- 4 - LOWER SCREW

- (5) Remove mounting ring and remove window crank, if equipped.
- (6) Open pocket door. (Fig. 19)

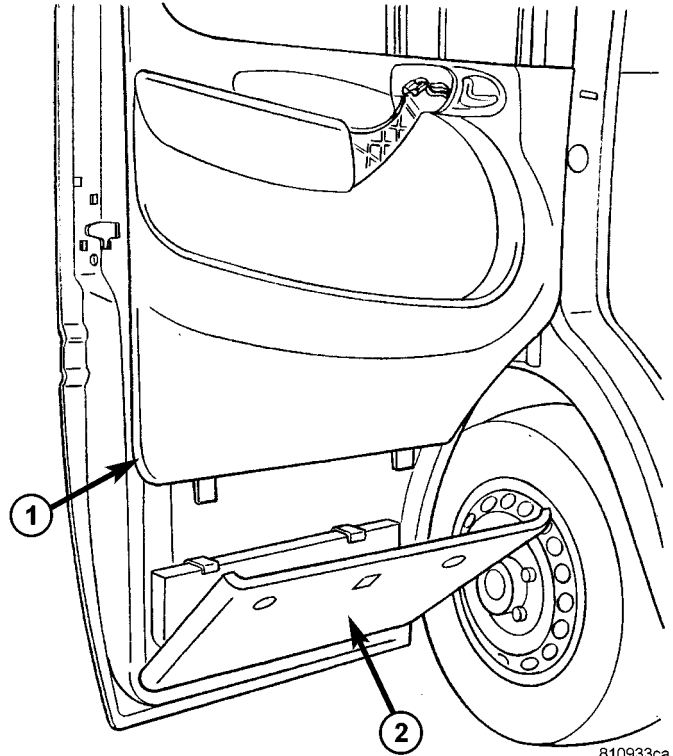

810933ca

Fig. 19 TRIM PANEL

- 1 - TRIM PANEL
- 2 - DOOR POCKET

TRIM PANEL (Continued)

(7) Using a trim stick C-4755 or equivalent, separate window frame molding from door. (Fig. 20)

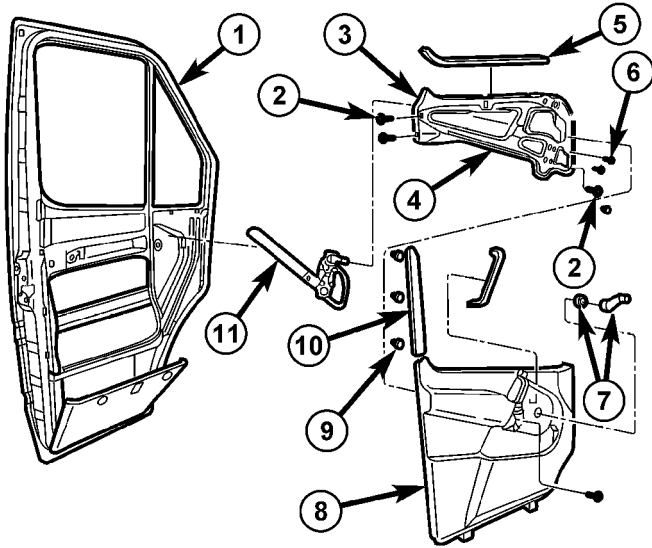

8111fd81

Fig. 20 MANUAL REGULATOR ASSEMBLY

- 1 - DOOR
- 2 - CARRIER PLATE BOLTS
- 3 - CARRIER PLATE
- 4 - REGULATOR ASSEMBLY
- 5 - SEALING STRIP
- 6 - REGULATOR RIVETS (4)
- 7 - WINDOW CRANK/TRIM RING
- 8 - TRIM PANEL
- 9 - CLIPS
- 10 - WINDOW FRAME MOLDING
- 11 - REGULATOR

(8) Slightly pull door trim upward and swing away slightly.

(9) Unlock retainer clip and disconnect control cable. (Fig. 21)

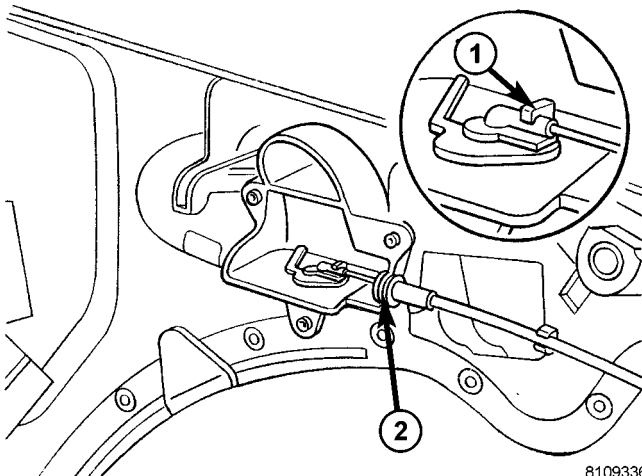

8109336e

Fig. 21 CONTROL CABLE

- 1 - RETAINER CLIP
- 2 - CONTROL CABLE MOUNTING

(10) Remove trim panel.

INSTALLATION

- (1) Position trim panel and connect control cable.
- (2) Install trim panel.
- (3) Position window frame molding and seat clips fully.
- (4) Close pocket door.
- (5) Install window crank and mounting ring, if equipped.
- (6) Install handle screws.
- (7) Connect electrical connectors and install switch bezel.
- (8) Install handle cover.
- (9) Connect battery negative cable.

WINDOW REGULATOR - POWER**REMOVAL**

- (1) Lower front window approximately 2 cm (3/4 in.).
- (2) Disconnect and isolate battery negative cable.
- (3) Remove door trim panel. (Refer to 23 - BODY/DOOR - FRONT/TRIM PANEL - REMOVAL)
- (4) Disconnect electrical connector. (Fig. 22)

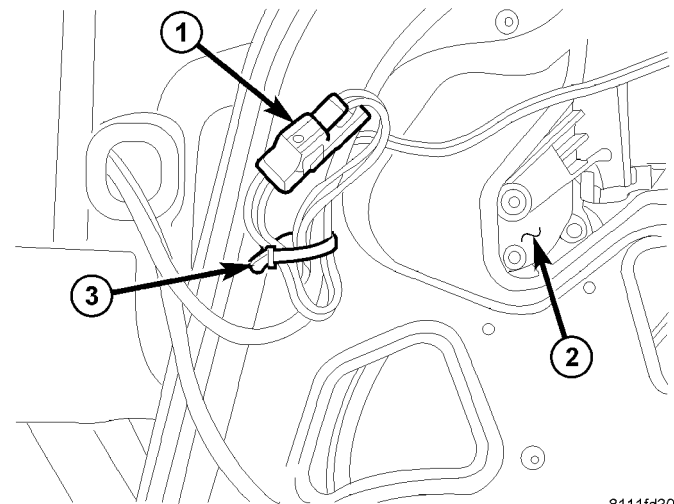

8111fd30

Fig. 22 ELECTRICAL CONNECTOR

- 1 - ELECTRICAL CONNECTOR
- 2 - REGULATOR MOTOR
- 3 - WIRE TIE